

ACVATIX™

Electromotoric actuators for valves

SAT..



Electromotoric actuators with 5.5 mm stroke and 300 N positioning force

- SAT31.. Operating voltage AC 230 V, 3-position control signal
- SAT61.. Operating voltage AC 24 V / DC 24 V, position signal DC 0...10 V / DC 4...20 mA / 0...1000 Ω
- For direct mounting on valves; no adjustments required
- Manual adjuster, position indicator and status indication per LED
- Optional functions with auxiliary switch

Application

For the operation of Siemens 2-port and 3-port valves:

- Type series VVG549..
- 5.5 mm stroke

As control or shutoff valves in heating and ventilation systems.

In conjunction with the ASK30 mounting kit, the former Landis & Gyr-valves with 4 mm or 5.5 mm stroke can also be operated: X3i.., VVG45.., VXG45.., VXG46.., VVI51...

Functions

Function	Description	Type
3-position control	A 3-position signal drives the actuator via connection terminals Y1 or Y2. The desired position is transmitted to the valve.	SAT31..
Modulating control	The modulating positioning signal drives the actuator steplessly. The positioning signal range (DC 0...10 V / DC 4...20 mA / 0...1000 Ω) corresponds in a linear manner to the positioning range (fully closed...fully open, or 0...100 % stroke).	SAT61..
Positioning signal and characteristic changeover	Setting the DIL switches. Factory setting SAT...: <ul style="list-style-type: none"> • Characteristic curve: lin = linear (switch at "ON") • Positioning signal: DC 0...10 V (switch at "OFF") 	
Position feedback U	Signal, returned to acquire the position via an input.	
Calibration	Conduct during initial commissioning. The actuator deploys to the top and bottom end position; measured values are saved.	
Detection of valve seat	Actuators have power-dependent seat detection. After calibration, the exact valve stroke is filed in the actuator's memory.	
Foreign body protection	After detection of clogging, 3 attempts are made to overcome clogging. If the attempts made are unsuccessful, the actuator continues to follow the positioning signal within the restricted range only (LED continues to blink red).	
Forced control Z (Z mode)	Forced control serves for overriding automatic mode and is implemented in the structure.	

Types

Type	Stock no.	Operating voltage	Positioning signal	Power consumption	Posit. time	Spring return function/time	Manual adjustment	Position feedback	Remark	
SAT31.008	S55158-A119	AC 230 V	3-position	5.0 / 2.5 VA ⁴⁾	8 s	No	Yes	-	1)	2)
SAT31.51	S55158-A120			5.5 / 3.2 VA ⁴⁾	15 s	Yes / <8 s ⁵⁾	No			
SAT61.008	S55158-A117	AC/DC 24 V	DC 0...10 V DC 4...20 mA 0...1000 Ω	7.1 / 4.6 VA ⁴⁾	8 s	No	Yes	DC 0...10 V		3)
SAT61.51	S55158-A118			6.4 / 4.8 VA ⁴⁾	15 s	Yes / <8 s ⁵⁾	No			

¹⁾ Cable gland: M16, M20 (ISO50262)

⁴⁾ Second value: Power consumption at normal position

²⁾ Approbation: CE

⁵⁾ Spring return time at low temperature is slightly longer

³⁾ Approbation: CE and UL (only 24 V)

Delivery

Actuator, valve and accessories are packed and supplied as separate items.

Accessories

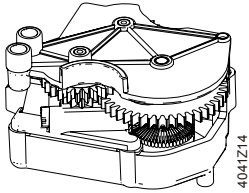
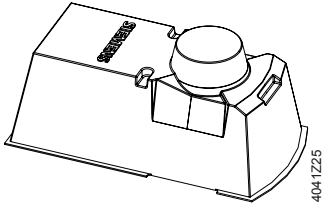
Electric accessories	Mechanical accessories
Auxiliary switch ASC10.51 	Weather shield ASK39.2 

Ordering (Example)

Type	Stock no.	Designation	Quantity
SAT31.008	S55158-A119	Actuator	1
+ auxiliary components (connections, auxiliary switches ·			

Spare parts

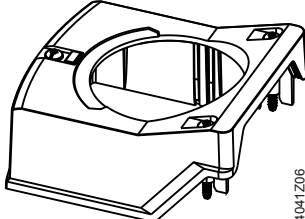
Stock no.	Description
S55845-Z180	Type ASQ1: Housing cover with screws and light guides as component, without laser labelling 

Compatibility

Valves PN25				Actuators SAT..		
VVG549... (2-port)	DN	G	K _{vs}	Δp _s	Δp _{max}	
Medium: 1...130 °C ¹⁾		[Inch]	[m ³ /h]	[kPa]	[kPa]	
VVG549.15-0.25	15	G ¾ B	0,25	2500	1200	
VVG549.15-0.4			0,4			
VVG549.15-0.63			0,63			
VVG549.15-1			1	1500		
VVG549.15-1.6			1,6			
VVG549.15-2.5			2,5			
VVG549.20-4K ²⁾	20	G 1 B	4	1600		
VVG549.25-6.3K ²⁾	25	G 1 ¼ B	6,3			

1) For a short time even up to +150 °C (up to 150 °C max. 6 of 24 hours)

2) Pressure compensated

Name	Topic	Document ID
SAS., SAT.. actuators for valves Basic documentation	Detailed information about the SAS.. actuators	CE1P4041en

Related documents such as environmental declarations, CE declarations, etc., can be downloaded at the following Internet address:

<http://siemens.com/bt/download>

Notes

Safety

	<p>⚠ CAUTION</p>
	<p>National safety regulations Failure to comply with national safety regulations may result in personal injury and property damage.</p> <ul style="list-style-type: none"> Observe national provisions and comply with the appropriate safety regulations.

Engineering

SAT31..

3-position actuators must have their own controller, see "Connection diagrams".

SAT61..

Up to 10 actuators can drive in parallel on a controller output with a rating of 1 mA. Modulating actuators have an input impedance of 100 kΩ.

Installation

Mounting positions

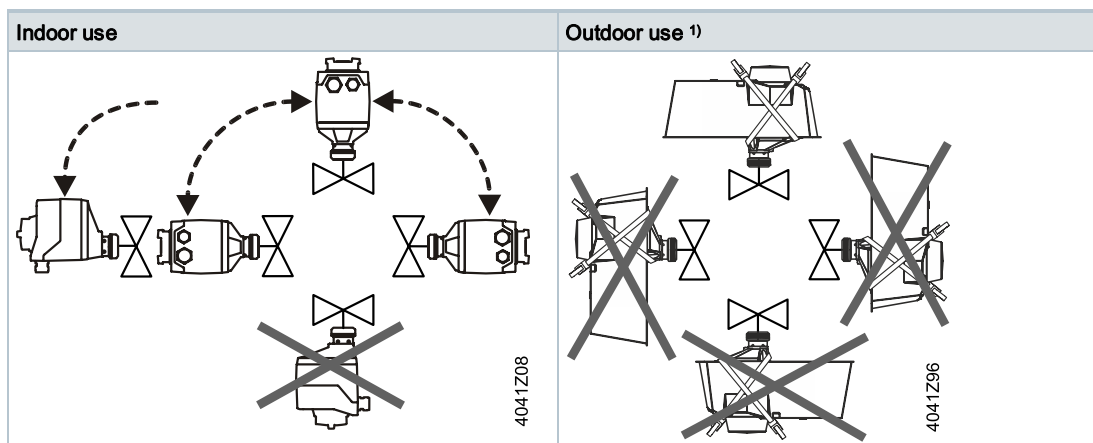

¹⁾ Requires the weather shield ASK39.2. Degree of protection of housing IP54 remains unchanged.

Maintenance



The SAT.. actuators are maintenance-free.

Mounting:

- Do not touch the valve coupling if the components (valve/pipes) are hot
- If necessary, disconnect electrical connections from the terminals

The actuator must be correctly fitted to the valve before recommissioning.

Disposal

	 WARNING
	<p>Tensioned return spring Opening the actuator housing can release the tensioned return spring resulting in flying parts that may cause injury.</p> <ul style="list-style-type: none"> • Do not open the actuator body.

	<p>The device is considered electrical and electronic equipment for disposal in terms of the applicable European Directive and may not be disposed of as domestic garbage.</p> <ul style="list-style-type: none"> • Dispose of the device through channels provided for this purpose. • Comply with all local and currently applicable laws and regulations.
---	--

Warranty

Technical data on specific applications are valid only together with Siemens products listed under "Equipment combinations". Siemens rejects any and all warranties in the event that third-party products are used.

Note

When using the actuators in connection with valves of other manufacture, correct functioning must be ensured by the user, and Siemens will assume no responsibility.

Technical data

Power supply		SAS..
Operating voltage	SAT31..	AC 230 V (±15 %)
	SAT61..	AC 24 V ± 20 % / DC 24 V +20 % / -15 % or AC 24 V class 2 (US)
Frequency		45...65 Hz
External supply line protection (EU)		Fuse slow 6 A...10 A or fuse switch max. 13 A, release characteristic B,C,D per EN 60898 power source with current limitation of max. 10 A
Power consumption	at 50 Hz	See "Type summary"; stem retracts/extends

Function data		
Positioning time for nominal stroke	SAT..008	8 s
	SAT..51	15 s
Positioning force		300 N
Nominal stroke		5.5 mm
Permissible medium	valve fitted	1...130 °C

Function data		
temperature		for a short time even up to +150 °C (up to 150 °C max. 6 of 24 hours)

Signal inputs		
Y positioning signal	SAT31..	3-position
	SAT61..	DC 0...10 V / DC 4...20 mA / 0...1000 Ω
	SAT61.. (DC 0· 10 V) Current draw	≤ 0.1 mA
	Input impedance	≥ 100 kΩ
	SAT61.. (DC 4· 20 mA) Current draw	DC 4...20 mA ± 1 %
	Input impedance	≤ 500 Ω

Parallel operation		
	SAT61..	≤ 10 (depends on controller output)

Forced control Z		
Positioning signal Z	SAT61..	R = 0...1000 Ω, G, G0
	R = 0...1000 Ω	stroke proportional to R
	Z connected to G	max. stroke 100 %
	Z connected to G0	min. stroke 0 %
	Voltage	Max. AC 24 V ±20 % / Max. DC 24 V +20 % / -15 %
	Current draw	≤ 0.1 mA

Position feedback		
U	Voltage range SAT61..	DC 0...10 V
	Load impedance	> 10 kΩ res.
	Load	max. 1 mA

Connecting cable		
Wire cross-sectional areas		0.75...1.5 mm ² , AWG 20...16 ¹⁾
Cable inputs	SAT.. (EU)	1 entry Ø 16.4 mm (for M16) 1 entry Ø 20.5 mm (for M20) Thread length max. 9mm

Degree of protection		
Housing		IP 54 per EN 60529
Insulation class		As per EN 60730
	Actuators SAT31.. AC 230 V	II
	Actuators SAT61.. AC/DC 24 V	III

Environmental conditions		
Operation		IEC 60721-3-3
	Climatic conditions	class 3K5
	Mounting location	Indoors, outdoors ²⁾
	Temperature general	-5...55 °C
	Humidity (noncondensing)	5...95 % r. h.
Transport		IEC 60721-3-2

Environmental conditions		
	Climatic conditions	class 2K3
	Temperature	-25...70 °C
	Humidity	<95 % r. F.
Storage		IEC 60721-3-1
	Temperature	-15...55 °C
	Humidity	5...95 % r. h.

Standards		
Product standard		EN60730-x
Electromagnetic compatibility (field of use)		For residential, commercial and industrial environments
EU conformity (CE)		CE1T4584xx ³⁾ (8000073403)
RCM conformity		CE1T4584en_C1 ³⁾ (8000069922)
UL, cUL	AC / DC 24 V	UL 873 http://ul.com/database
EAC conformity		Eurasia conformity for all SAT variants

Environmental compatibility	
	Environmental Declaration CE1E4584en contains data on environmental-compatible product design and assessment (RoHS compliance, compositions, packaging, environmental benefits and disposal)

Dimensions / Weight	
	Refer to "Dimensions"

Accessories ⁴⁾		
Auxiliary switch ASC10.51	Switching capacity	AC 24...230 V, 6 (2) A, potential free
	External supply line protection	See section power supply
	US Installation, UL & cUL	AC 24 V class 2, 5 A general purpose

1) AWG = American wire gauge.

Wire cross-sectional areas and fuses have to be matched, which is the responsibility of the planner/installer.
Observe standard on protection measures – Protection against overcurrent:
IEC 60364-4-43:2008 or German adoption HD 60364-4-43:2010.

2) Outdoors use only with weather shield ASK39.2, degree of protection of housing IP 54 remains unchanged

3) The documents can be downloaded at the Internet address, see Section 'Product documentation'.

4)

UL recognized component



Internal diagrams

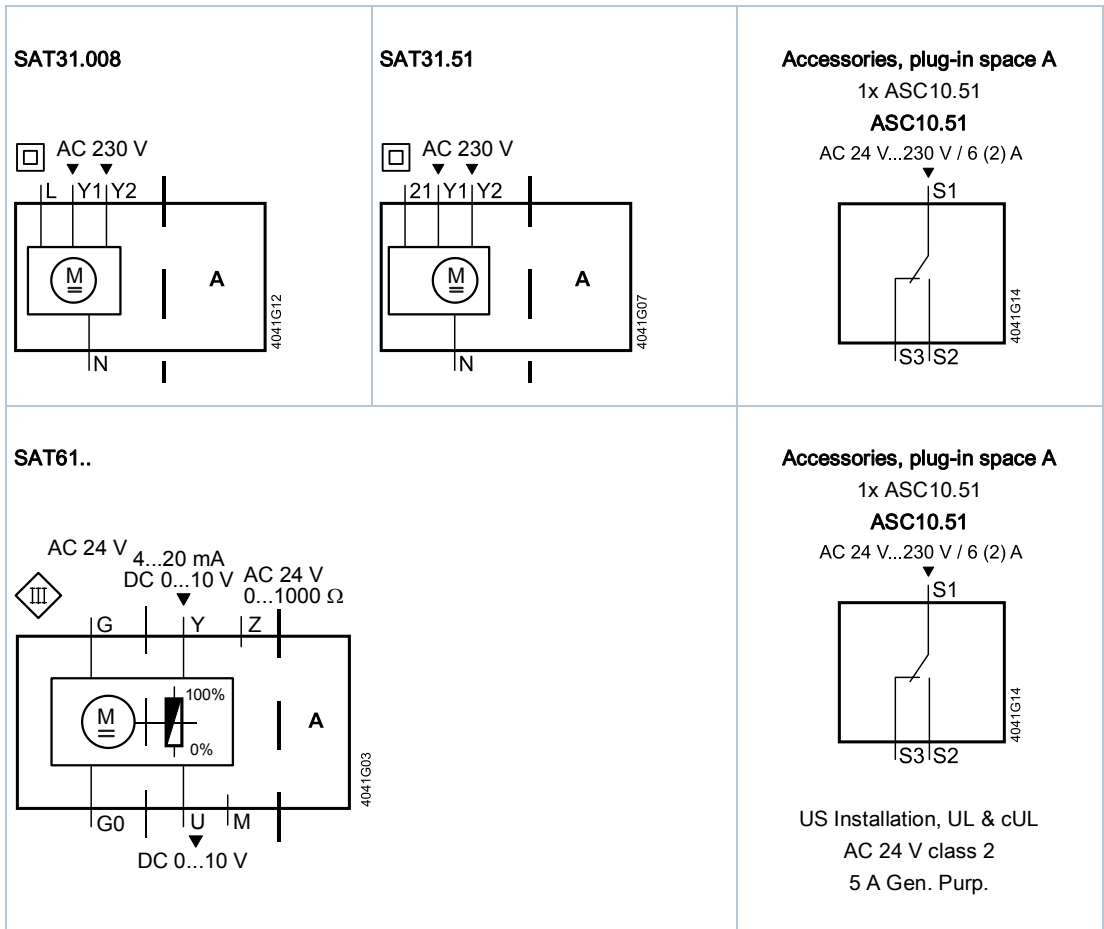

Connection terminals

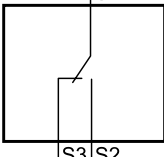
SAT31.008		AC 230 V, 3-position
4041297	N	System neutral (SN)
	Y1	Position signal (actuator stem extends)
	Y2	Position signal (actuator stem retracts)
	L	System potential (SP)
SAT31.51		AC 230 V, 3-position
4041282	N	System neutral (SN)
	Y1	Position signal (actuator stem extends)
	Y2	Position signal (actuator stem retracts)
	21	Fail safe function
SAT61..		AC/DC 24 V, DC 0...10 V / 4...20 mA / 0...1000 Ω
4040216	G0	System neutral (SN)
	G	System potential (SP)
	Y	Position signal for DC 0...10 V / 4...20 mA
	M	Measuring neutral
	U	Position feedback DC 0...10 V
	Z	Positioning signal forced control AC/DC ≤ 24 V, 0...1000 Ω
Electric accessories		
ASC10.51		Auxiliary switch. Adjustable switching points, AC 24...230 V
4040237	1	System potential (SP)
	2	Closes (actuator stem extends)
	3	Opens (actuator stem extends)
		AC 24 V...230 V / 6 (2) A 

Connection diagrams

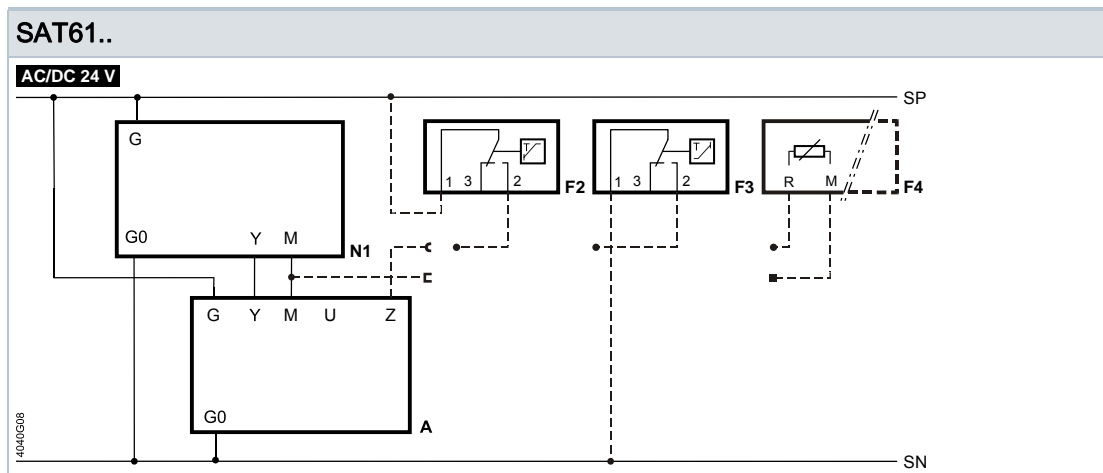
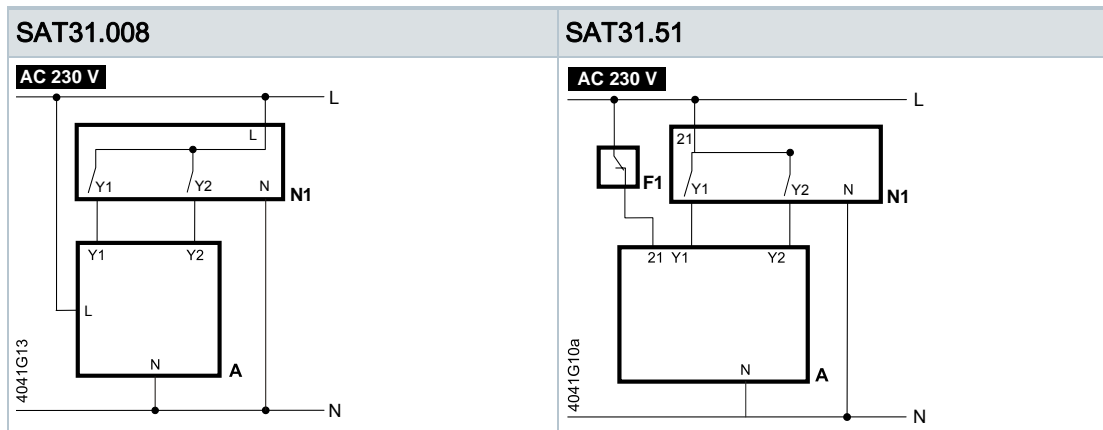

A	Actuator	N1	Controller
F1	Temperature limiter	SN	System neutral
F2	Frost protection thermostat; terminals: 1 – 2 Frost hazard/sensor is off (thermostat closes for frost) 1 – 3 normal mode	SP	System potential AC/DC 24 V
F3	Thermal reset limit thermostat	U	Position feedback
F4	Frost protection monitor with 0...1000 Ω signal output, does NOT support QAF21.. or QAF61..	Y	Positioning signal
L	Phase	Y1, Y2	Positioning signals
M	Measuring neutral	Z	Positioning signal forced control
N	Neutral	21	Fail safe function

Actuators SAT.. with manual adjuster

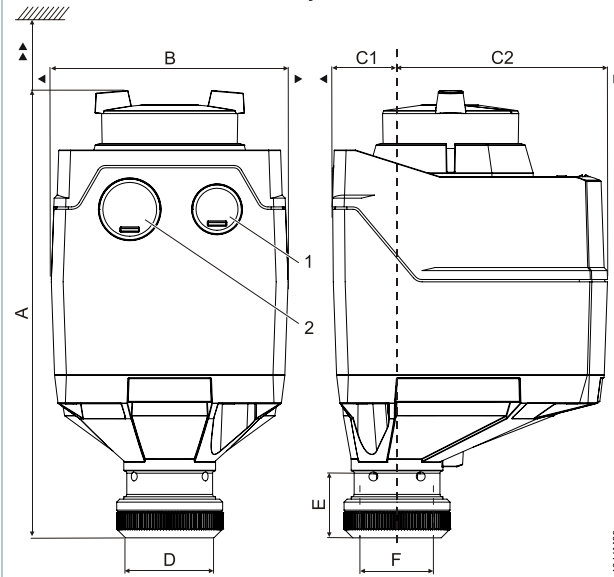

Type	A [mm]	B [mm]	C [mm]	C1 [mm]	C2 [mm]	D [mm]	E [mm]	F [Inch]	▶ [mm]	▶▶ [mm]	kg [kg]	1	2
SAT..	151	80	93	21,9	71.1	29,9	21,8	G ¾	100	200	0,4	M16 ¹⁾	M20 ¹⁾
With ASK39.2	155	126	248	99	149						0,55		

1) Thread length max. 9mm

Actuators SAT.. without manual adjuster

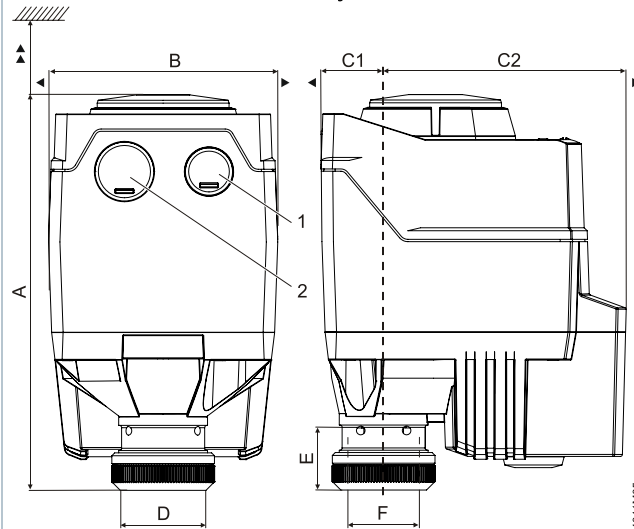

Type	A [mm]	B [mm]	C [mm]	C1 [mm]	C2 [mm]	D [mm]	E [mm]	F [Inch]	▶ [mm]	▶▶ [mm]	kg [kg]	1	2
SAT..	137,6 ¹⁾ 151 ²⁾	80	106,5	21,9	84,6	29,9	21,8	G ¾	100	200	0,68	M16 ³⁾	M20 ³⁾
With ASK39.2	155	126	248	99	149						0,83		

1) Black cover

2) Blue manual adjuster

3) Thread length max. 9mm

Revision numbers

Type	Valid from rev. no.
SAT31.008	..B
SAT31.51	..B
SAT61.008	..B
SAT61.51	..B

Issued by
Siemens Switzerland Ltd
Building Technologies Division
International Headquarters
Gubelstrasse 22
CH-6301 Zug
Tel. +41 58-724 24 24
www.siemens.com/buildingtechnologies

© Siemens Switzerland Ltd, 2015
Technical specifications and availability subject to change without notice.